



# Condensing Boiler Aldens



105 - 130 - 150 kW



# Aldens



LOW EMISSION LEVEL  
**ECO-FRIENDLY  
BOILER**

## Wall Type Premix Condensing Boiler

### Elegant and Modern Design

- Very small dimensions for its capacity
- Elegant control panel with Turkish menu
- Exchanger maintenance without draining boiler or heating system water even while the heating system is under pressure
- Patented and specially developed exchanger hanger system
- Utility model certified control board protection box
- All electrical network and signal outputs required are carried to the rear of the front panel box with terminals for ease of connection



## Features of Aldens

- High condensation efficiency up to 109%
- Ideal gas-air mixture, high efficiency, low noise level, low flue gas temperature and low emission rate thanks to the premix system, environmentally friendly product
- Capacities of 105, 130 and 150 kW ( at 50/30°C)
- Massive project solutions with cascading capability up to 16 x 16 = 256 units and 38.400 kW
- Minimum stop and start operations, maximum fuel saving with the very extensive heating modulation range (19 to 100%)
- High efficiency proved by the very low flue gas temperature (flue gas temperature reduced up to 31.4°C)
- Durable stainless steel exchanger with long service life
- Natural gas compatible
- Certified for EMC (Electro Magnetic Compatibility) and LVD (Low Voltage Directive)
- 6 bar maximum operating pressure
- 6 bar safety valve and expansion tank connection T piece are provided free of charge in each boiler package
- Complies with EN 15502 norm (gas fired boilers with a rated heat load under 1,000 kW)

## For All Requirements Quick and Quality Feedback

Cascade and expansion modules that may be required as an accessory as per the installation requirement are very small and installed to their seats already available in the boiler. On the modules installed to the wall of the boiler room problems of fixing on the wall or boiler room electric distribution panel and long cabling are dismissed.

Wide range of accessories with reasonable price (control module and sensors, flue and flue accessories, high energy class pumps, pump connection sets, neutralisers, hanger console set)

Convenience for creating projects with hydraulic header selection program and sample (autocad) installation application drawings.

Ease of service provided by capabilities such as easy and quick module connections, quick exchanger maintenance without draining heating system water

Wide service network... Competitive prices...

Cheap spare parts...

**Cascading  
capability  
up to  
38.400 kW**



## Very High Performance With the Cascade System

Operation of more than one boilers in harmony instead of a single big boiler for high capacity central heating systems in apartment blocks and development sites is called "cascade system."

Cascade system is controlled by the electronic board inside the boilers and the cascade modules continuously communicating with each other.

### **CONTINUOUS OPERATION**

As the boilers are installed in cascade, heat is provided automatically by the other boilers connected in series in case of a fault. System operates continuously.

- Heat demand of whole system is informed to the lead boiler (master boiler with 1 as the address number). Heat demands are transferred to the cascade sensor and as per the heat requirement information taken from this sensor follower boilers (slave boilers) are also activated by their turn. Activation of other boilers is calculated using an integral.
- System has equal aging feature for the boilers. For 500 hours (factory setting) 1st boiler (master boiler) is activated first with leading role when heat is required. After this period, leadership is transferred to the 2nd boiler in the row, and this boiler takes the leading role for 500 hours, too. Thus, boilers have the same service lives.





- Strategy of cascade operation is “Activate early, deactivate late.” In case of heat requirement, master boiler activates with minimum output band (40%) and goes up to 90% capacity maximum. If the heat requirement cannot be provided by a single boiler, slave boiler is activated, and both boiler operate together, the same applies for the rest. This means that many boilers are activated and additional boilers are kept active for the longest possible time.
- LMS14 boiler control board can perform cascading up to 16 boilers in a single segment. Total number of segments is 16, and thus a cascade system of  $16 \times 16 = 256$  boilers may be controlled. Each segment has a master boiler and a cascade sensor.

To obtain proper combustion from a boiler for the heat requirement of the building at that time, i.e. modulation, it is important that the air and gas are controlled separately from each other with a good electronic sensing and control system.

With modulation:

- Stop-start operation of the boiler is prevented, Heating comfort is increased,
- System losses are minimized,
- Emission of harmful substances generated during combustion are reduced.

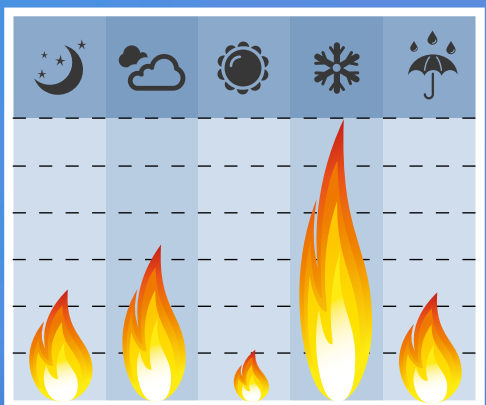

With a real modulation, appliance can be operated with the highest efficiency, not only during a season, but on various weather conditions, transitional seasons, night and day periods.

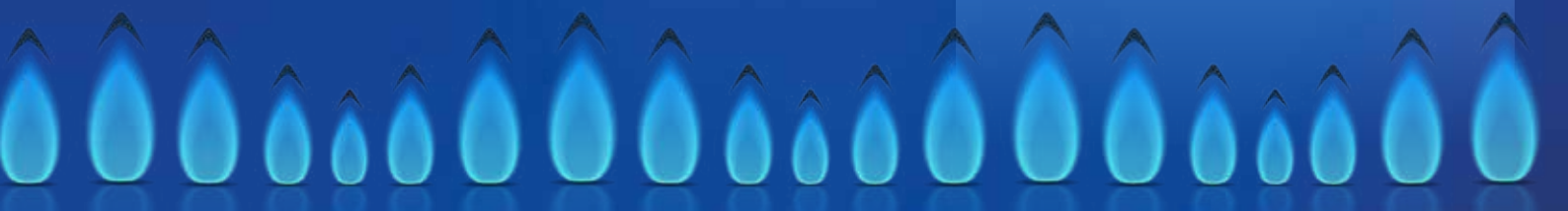



ALDEN L





Notification with LED Illumination

### ALDENS T



**Fault condition**  
(Red LED flashes)



**First power connection / parameters are loading**  
(Red and blue LEDs are on together)



**Off / burner is not operated**  
(LED display is off)



**Burner activated**  
(Blue LED is on continuously)

## IMPORTANT COMPONENTS

Aldens condensing boilers consist of superior segment components with long service life manufactured by specialist brands and that have been favoured by the manufacturers, users and services throughout the world. Boilers are equipped with thermostats and sensors for maximum safety and ideal control.

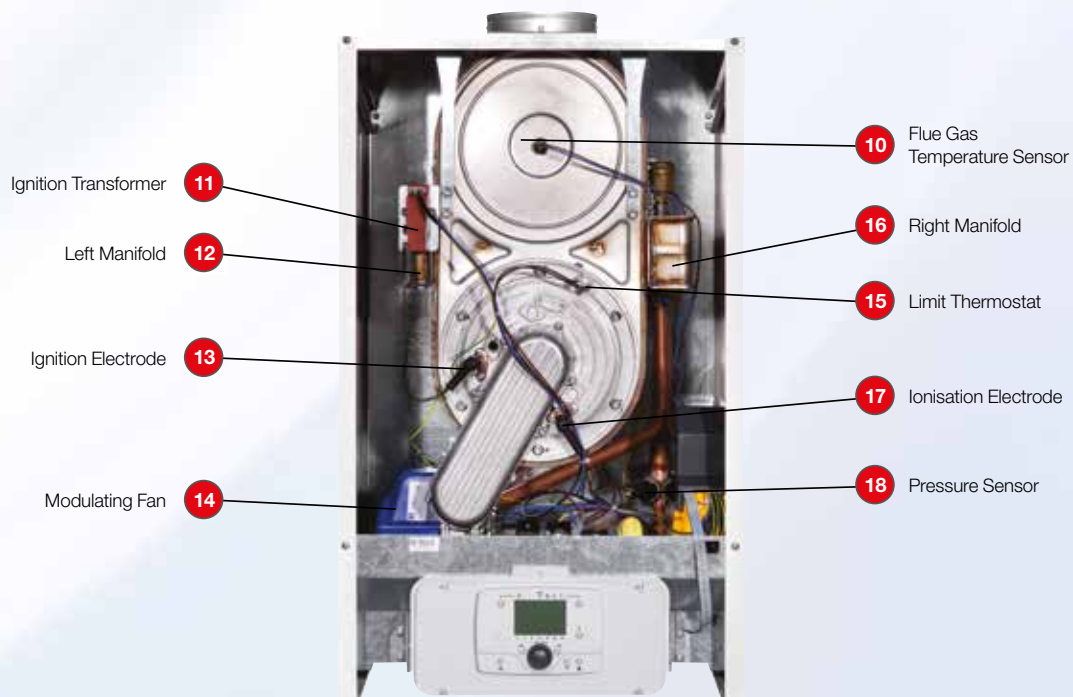



## HEAT EXCHANGER

### Quiet, Long Service Life and Environmentally-Friendly

- **Sermeta** brand exchanger with low CO<sub>2</sub> footprint can be 100% recycled.
- Made of cylindrical, smooth stainless steel with long service life.
- It has high efficiency, and it is durable and resistant against thermal shocks.
- Three different types of exchangers are used for 105, 130 and 150 kW.
- Exchanger's burner is the patented, very quiet Bluejet® burner with a long service life developed by Sermeta.
- Quick maintenance is possible with easy access to combustion chamber by removing a few nuts.

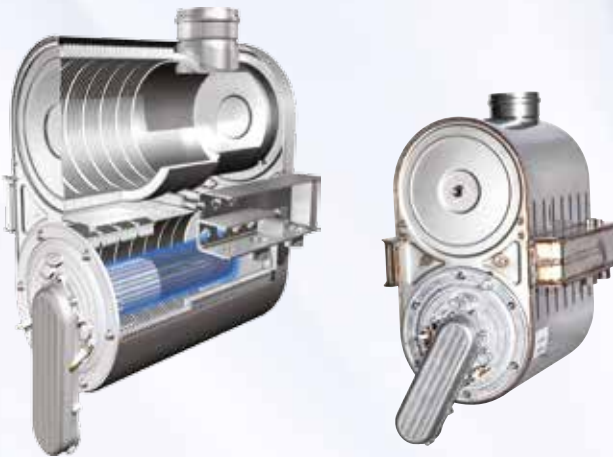

## Operating Diagram

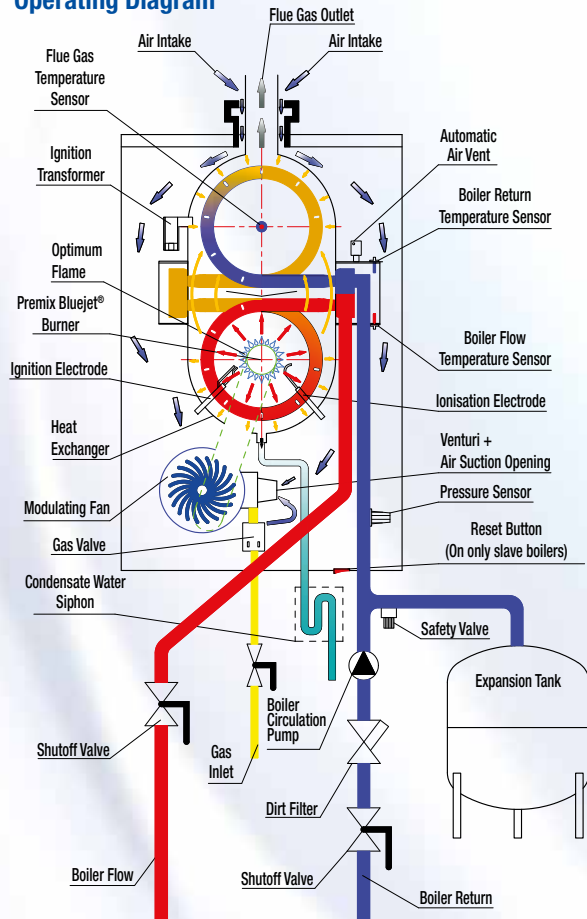

## MAIN BOARD

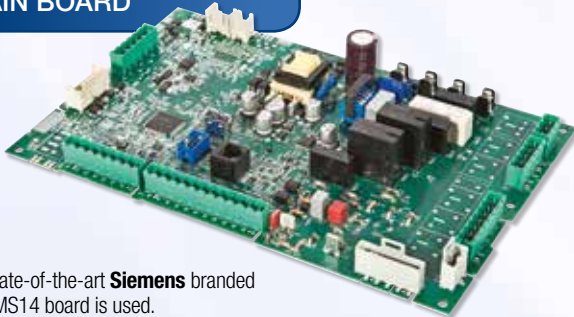

- State-of-the-art **Siemens** branded LMS14 board is used.
- Control of heating, domestic hot water and solar energy applications
- Protection of heat exchanger from thermal stresses with the excess  $\Delta T$  (delta T) prevention system
- Parameter loading with the parameter stick
- Time scheduling for heating, boiler and an external relay
- Capability of connecting up to 256 cascade boilers aged equally
- With the activate early, deactivate late system in cascade operation, more than one boilers are activated and thus, minimum system modulation rate and highest efficiency are obtained
- Control of additional circuits with the capability for connecting 3 expansion modules
- 1 pc. of 230V energy outlet
- 3 pcs. of 230V relay outlets: Staged boiler pump, direct circuit pump and DHW tank pump (1 three-way valve for diverting on/off operation may connect)
- Modulating pump control with 1 PWM (pulse width modulation) connection
- 4 empty sensor connections (outside, cascade and DHW tank sensors are assigned, and one unassigned)
- 3 digital inlets (e.g. on/off control for 3 different heating circuits with 3 room thermostats or swimming pool control)
- Changing of comfort/economy mode and boiler water temperature for 2 different heating circuits with 2 internal room unit connections
- Date, day of the week, time settings
- Vacation program
- Setting and intervention capability with four different user levels (End user, first start-up, engineer and factory OEM)

## FAN-VENTURI ASSEMBLY

- Required amount of air-gas mixture is obtained as per the boiler capacity with **SIT** branded modulated fan. Fan speed is increased or decreased as per capacity. Thus, both low noise level is maintained and reduction in efficiency caused by excess air is prevented.
- **Honeywell** branded venturi allows keeping the ideal air-gas mixture ratio of 1:10 constant for the whole capacity range. This is the most important point that ensures efficient and clean burning.



## GAS VALVE

- **Honeywell** branded gas valve provides the gas flow required as per the speed of the modulating fan that changes as per capacity safely.
- In case of a power outage, power supply of the gas valve is turned off too, and valve closes automatically within 1 second maximum thanks to its mechanical properties.
- Same applies for the conditions where boiler shall turn off the gas valve for safety reasons.



# High Level Of Safety

## FULL CONTROL

### CONTROL MODULE, SENSOR AND ACCESSORIES



#### OCI345.06/101 Cascade Module

It shall be available in each boiler in the system for multiple boiler control in cascade systems. It is installed to the slave boilers (T) in factory. Therefore, only 1 is required per cascade for the master (L) boiler to be used in the cascade system.

#### AGU2.550x109 Expansion Module

Used for 1 mixture circuit control (3-way mixing valve + pump + flow sensor) or 3 direct circuit pump supplies. There is 1 additional sensor outlet (for solar collector sensor or swimming pool sensor etc.). 3 expansion modules may be connected on each boiler.



#### QAC34/101 Outside Sensor

User for operation of boilers according to the outside weather conditions. These are essential in each system.



#### QAZ36.522/109 Immersion Type Sensor

It is used as DHW tank sensor, hydraulic header sensor etc.

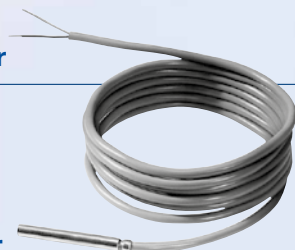

#### QAZ36.481/101 Immersion Type Sensor

Used as solar collector sensor. It may measure up to 200°C.





# Respect For Environment Reachable Quality

## QAZ36.481/101 Strap-On Type Sensor

It is used as flow and return water sensor. Placed on the flow after the exchanger if plate exchanger is used as the primary - secondary circuit separator.



## QAA55 Internal Room Unit

Used for zone control (direct circuit or mixture circuit). Mode change, increase / decrease of boiler water temperature are possible. 2 internal room units may be connected to each boiler.



## RAA 21 Room Thermostat

Used for zone control. Operates the boiler according to the set temperature (direct circuit or mixture circuit). 3 room thermostat connections in total are available in each boiler.



## OZW672 Web Server

System control, monitoring and setting operations are possible by connecting single boiler or cascade systems remotely via the web server by a computer or a smart phone. Different types that can control 1 device, 4 devices maximum and 16 devices maximum (OZW672.01/04/16). Error messages and periodical reports are sent to up to 4 users registered in the system with e-mail.



## RVS 61.843/109 Controller and OCI350.01/101 Modbus Communication Module

Used for communication with Modbus building management system. Information is transferred to building management system via RVS61.



# ACCESSORIES

## Boiler Circulation Pumps

High energy class PWM connected (modulating) 3 or fixed/variable pressure setting pumps with EEI (Energy Efficiency Index)  $\leq 0,23$  selected as per header or plate exchanger usage alternative are used as accessories with Aldens boilers.

## Pump Connection Sets

Connection sets are provided for easy connection of pumps to Aldens boilers. It has two diameters which are 1 1/4" - 1 1/2" for Aldens 105 and 1 1/4" - 2" for 130-150 types.

5	KLINGERITE GASKET 2"
4	PUMP UNION 1 1/4" - 2"
3	NIPPLE 1 1/4"
2-b	NIPPLE REDUCTION 1 1/4" - 2"
2-a	NIPPLE REDUCTION 1 1/4" - 1 1/2"
1	SLEEVE 1 1/4"

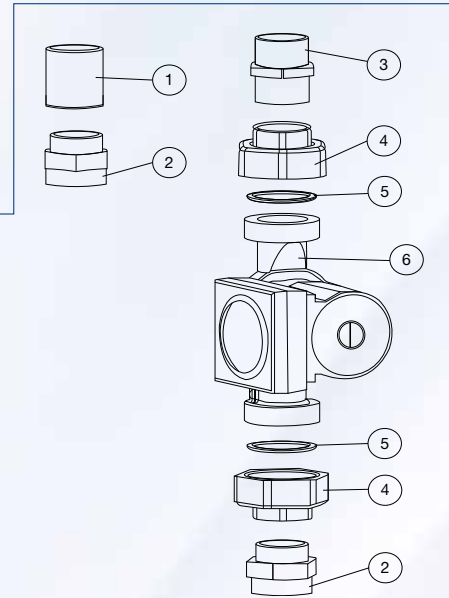

## Neutralizers



Usage of neutralizers which neutralize the acidic condensate water is mandatory for installations of 200 kW or above.

For natural gas the pH value before the neutralization process is between 3.5 – 4.0.

The pH value after the neutralization process is between 6.0 – 7.0. Neutralizers are available in three models:

- for < 150 kW Neutrakon® 03/150
- for < 300 kW Neutrakon® 04/BGN with auxiliary pump and
- for < 650 kW Neutrakon® 08/BGN with auxiliary pump

## Neutralizer Inlet Elbow

Used for connection of condensate water hose to the neutralizer.

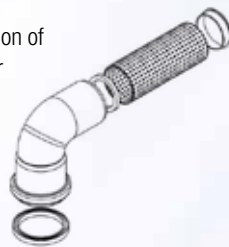

## Flue Gas Clack

Installed in each boiler in cascade flue systems with over pressure to prevent flue gas ingress to the boilers that are not being operated



## 6 Bar Safety Valve

Usage of safety valves in each boiler is mandatory. A 6 bar safety valve is provided with each boiler package. With the addition of expansion tank connection integrated to it, provides saving on accessory costs and labour.



## Air Intake Grill

Installed on each boiler to prevent ingress of live animals or foreign matters such as paper, cloth etc when air required for combustion is taken from the boiler room.

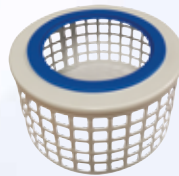

## Hanger Console Set

Used when boiler room wall cannot carry the weight of the boilers or when boilers shall be hung on back to back to save space. It has a modular structure, and may be duplicated as back-to-back and side-by-side. Made of material complying with DIN 59411 standard and durable rectangular profiles. It has RAL9006 grey colour. Has lugs for fixing both on the ground and the wall that it shall be leaned on.

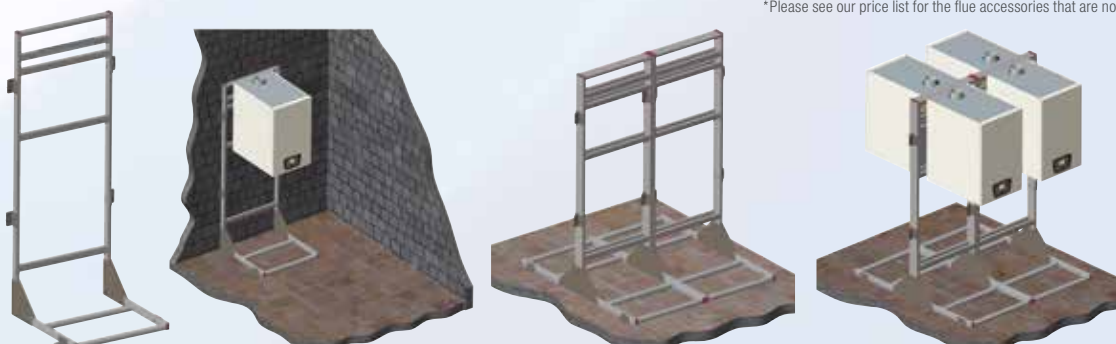

\*Please see our price list for the flue accessories that are not specified here.

## FLUE CONNECTION TYPES

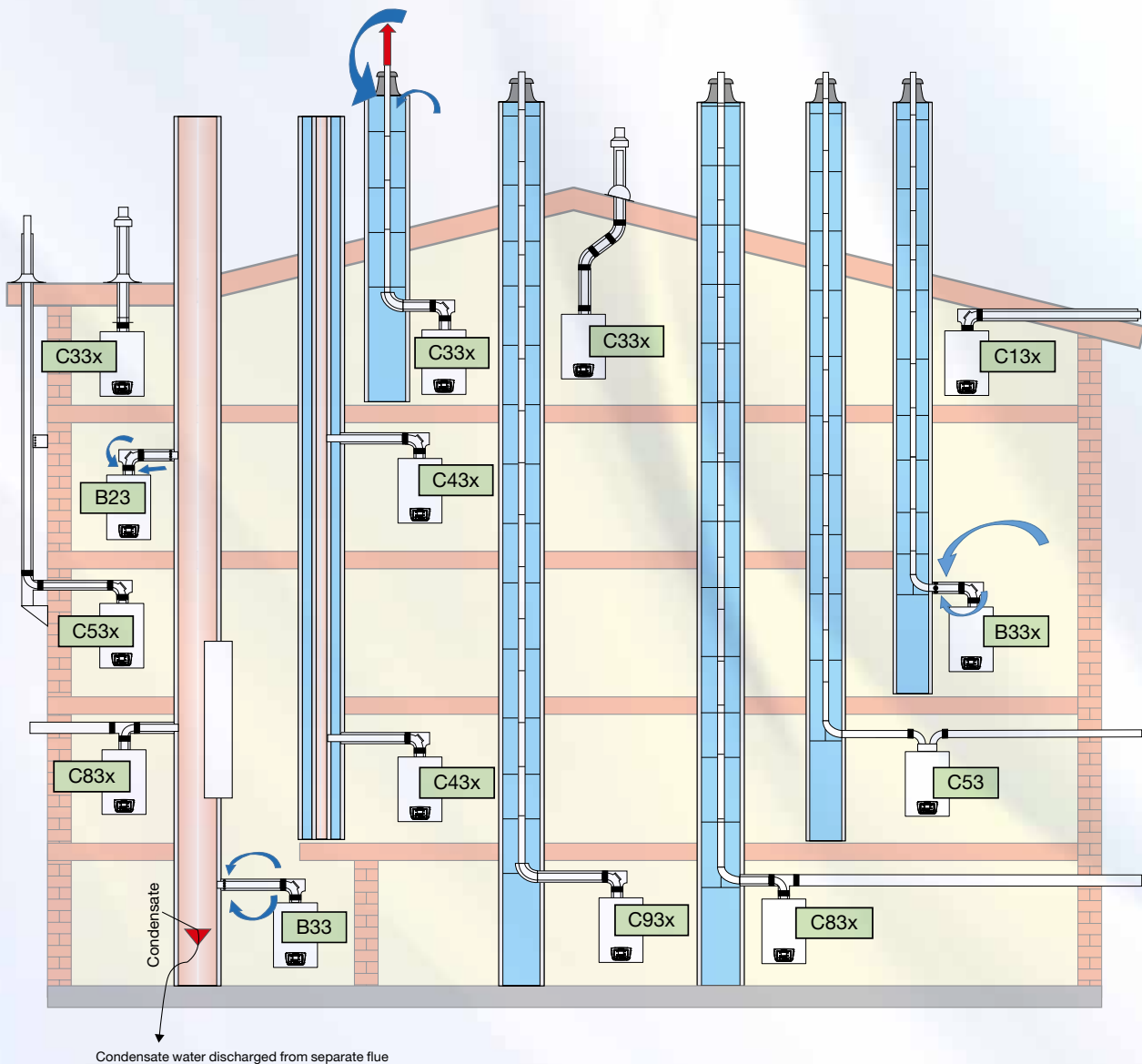

Flue Type	Description
B23	Flue gas pipe through the chimney, combustion air directly from the location through the device (open type)
B23	2 piece cascade flue gas pipe through the chimney, combustion air directly from the location through the device (open type)
B33	Flue gas pipe through the chimney, combustion air from the location, with horizontal concentric connection (open type)
B33	Horizontal concentric pipe connection to the condensation resistant flue, combustion air from the location (open type)
C13x	Horizontal concentric roof transition application for slant roof (hermetic type)
C33x	Vertical concentric roof transition from slant or level roof (hermetic type)
C43x	Connection to combustion air / flue gas shaft resistant to condensation, maximum horizontal pipe length from elbow center of the appliance to the flue connection is 2m. (hermetic type)
C53	Flue gas pipe through the chimney, combustion air from the shaft, horizontal concentric connection (hermetic type)
C53x	Discharge from roof by taking the flue gas pipe through outer face (hermetic type)
C83x	Flue gas pipe through the chimney, combustion air from the shaft, horizontal concentric connection (hermetic type)
C83x	Concentric connection to the condensation resistant chimney, combustion air from the external environment (hermetic type)
C93x	Flue gas pipe through the shaft, combustion air from the shaft, horizontal concentric connection (hermetic type)

# SAMPLE INSTALLATION DIAGRAMS

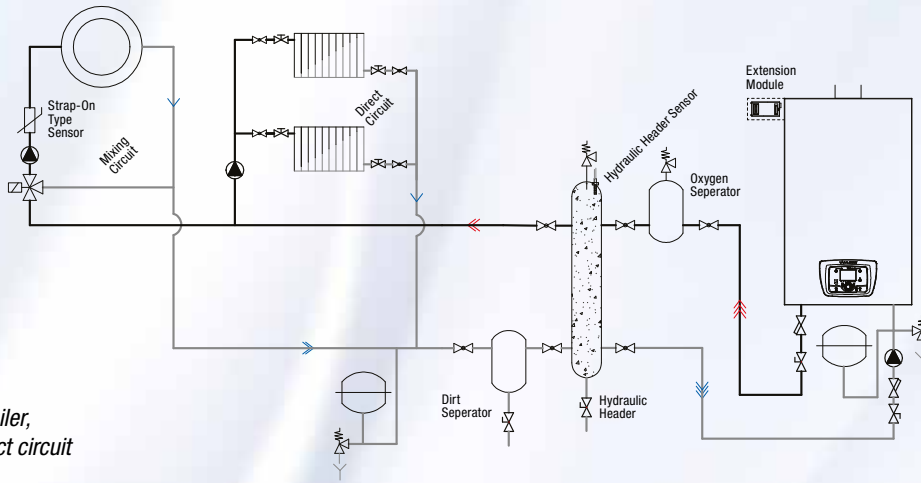

*Installation diagram of 1 boiler,  
1 mixture circuit and 1 direct circuit  
with hydraulic header*

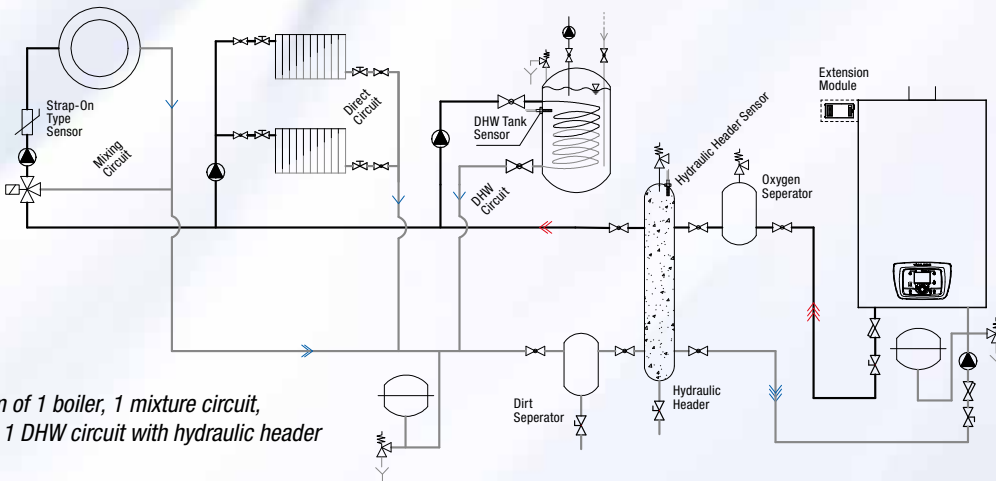
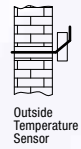

*Installation diagram of 1 boiler, 1 mixture circuit,  
1 direct circuit and 1 DHW circuit with hydraulic header*

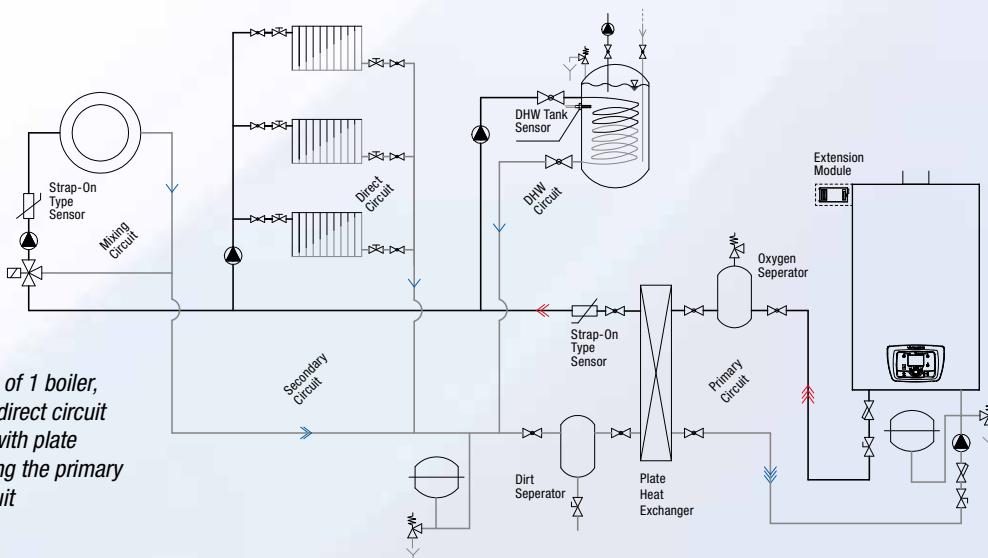
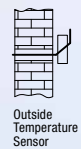

*Installation diagram of 1 boiler,  
1 mixture circuit, 1 direct circuit  
and 1 DHW circuit with plate  
exchanger separating the primary  
and secondary circuit*

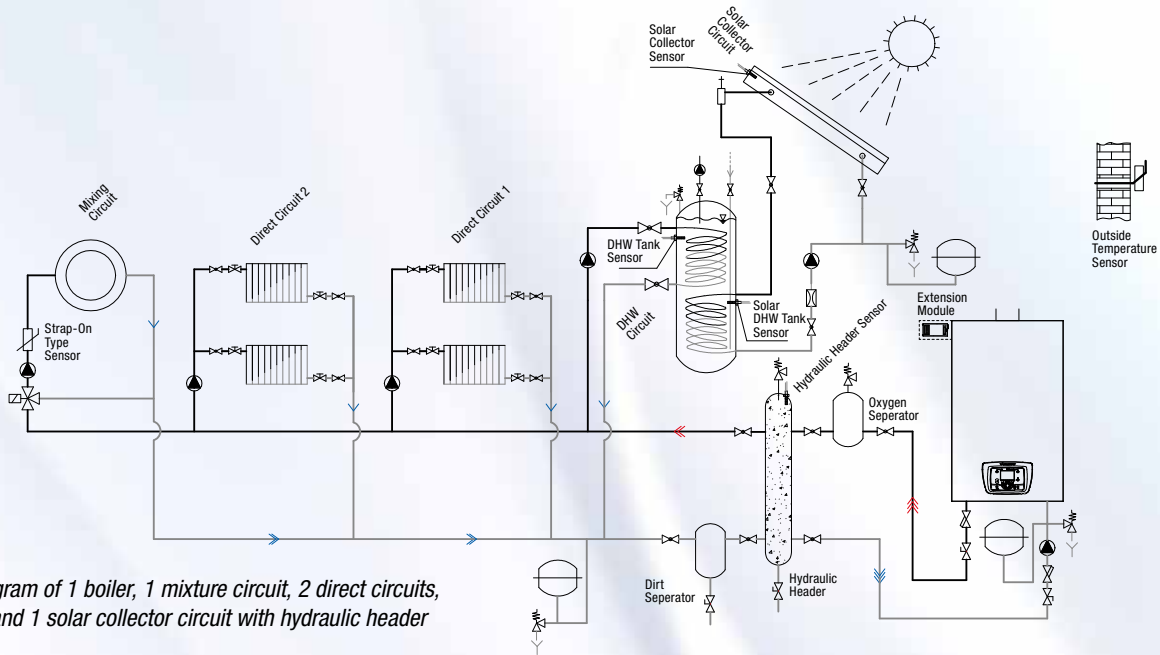

*Installation diagram of 1 boiler, 1 mixture circuit, 2 direct circuits, 1 DHW circuit and 1 solar collector circuit with hydraulic header*

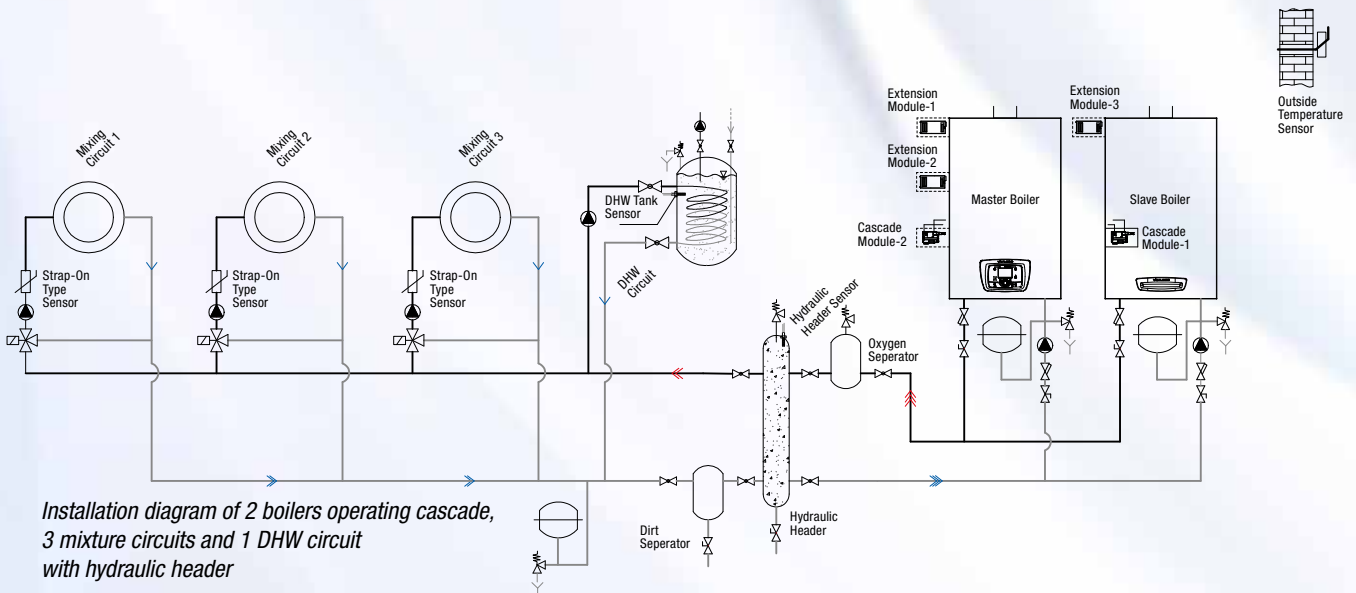

*Installation diagram of 2 boilers operating cascade, 3 mixture circuits and 1 DHW circuit with hydraulic header*

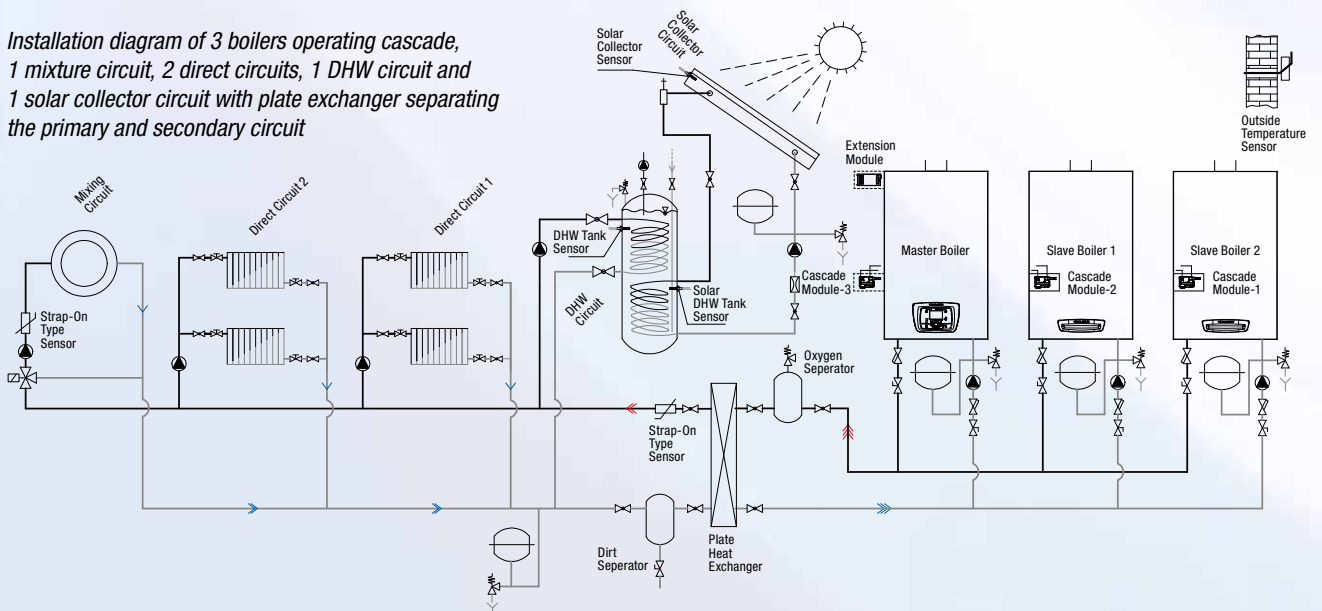

*Installation diagram of 3 boilers operating cascade, 1 mixture circuit, 2 direct circuits, 1 DHW circuit and 1 solar collector circuit with plate exchanger separating the primary and secondary circuit*

## Dimensions



## Bottom View

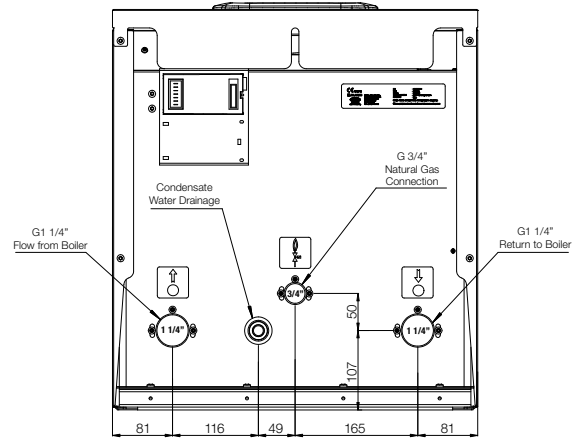

TECHNICAL SPECIFICATIONS	UNIT	ALDENS 105	ALDENS 130	ALDENS 150
<b>Boiler Types</b>		MASTER (L) / SLAVE (T)	MASTER (L) / SLAVE (T)	MASTER (L) / SLAVE (T)
<b>Fuel</b>		Natural Gas (G20)	Natural Gas (G20)	Natural Gas (G20)
Inlet Pressure	mbar	21	21	21
Fuel Consumption at Maximum Load	m <sup>3</sup> /h	10,2	12,9	15
Fuel Consumption at Minimum Load	m <sup>3</sup> /h	2	2,5	2,9
<b>Power / Efficiency</b>				
Maximum / Minimum Power (50/30°C)	kW	105 / 20	130 / 25	150 / 30
Maximum / Minimum Power (80/60°C)	kW	95 / 17,5	118,3 / 22	135,8 / 26
Power at Ignition	kW	46	46,3	64,4
Efficiency (50/30°C – Maximum / Minimum Load)	%	107,64 / 109,23	105,48 / 108,06	106,95 / 108,80
Efficiency (80/60°C – Maximum / Minimum Load)	%	97,37 / 96,26	96,00 / 95,78	96,80 / 96,36
<b>Flue Pressure / Waste Gas Flow Rate</b>				
Flue Pressure (Maximum / Minimum Load)	Pa	160 / 60,2	410 / 98,2	455 / 103,5
Flue Pressure (Ignition)	Pa	74	108	131
Flue Gas Flow Rate (Max. / Min. Load)	g/s	42,6 / 8	55,4 / 10,4	59,5 / 11,6
CO <sub>2</sub> Concentration (Max. / Min. Load)	%	8,99 / 9,25	8,90 / 8,96	9,52 / 9,32
Flue Gas Temperature (Max. / Min. Load)	°C	60,2 / 32,8	64,9 / 32,7	58,6 / 31,4
<b>Electrical Specifications</b>				
Power Supply (Voltage/Frequency)	VAC/Hz	230 / 50	230 / 50	230 / 50
Fuse to be used	A	6,3	6,3	6,3
Power consumption at off mode	W	2	2	2
Fuel Consumption at Maximum / Minimum Load	W	125 / 25	220 / 27	263 / 28
<b>Hydraulic Connections</b>				
Gas Connection	inch	¾"	¾"	¾"
Heating Flow / Return	inch	1 ¼"	1 ¼"	1 ¼"
Maximum Operating Pressure	bar	6	6	6
Minimum Operating Pressure	bar	1	1	1
Maximum Load 50/30°C – Boiler Resistance	mSS	5,62	4,49	4,68
Maximum Load 80/60°C – Boiler Resistance	mSS	4,52	3,58	3,64
Minimum Load 50/30°C – Boiler Resistance	mSS	0,35	3,50	0,31
Minimum Load 80/60°C – Boiler Resistance	mSS	0,26	3,00	0,24
Boiler Filling (Exchanger) Water Capacity	l	8,5	10	12,5
<b>General Specifications</b>				
Appliance Dimensions (Width x Depth x Height)	mm	492 x 540 x 841	492 x 705 x 841	492 x 705 x 841
Package Dimensions (Width x Depth x Height)	mm	565 x 910 x 765	565 x 910 x 925	565 x 910 x 925
Weight of the Appliance (Empty / Full)	kg	81,2 / 89,7	91,6 / 101,6	103,6 / 116,1
Packaged Weight	kg	94	105	117
Flue Diameter (Flue Gas Outlet / Air Intake)	mm	100 / 150	100 / 150	100 / 150
NOx Class		5	5	5
Type		Hermetic / premix condensing	Hermetic / premix condensing	Hermetic / premix condensing
Control Panel		Electronic and with keys	Electronic and with keys	Electronic and with keys
Ignition System		Electronic	Electronic	Electronic
Fault Detection and Warning System		YES (error code on the display)	YES (error code on the display)	YES (error code on the display)
Compatibility with Underfloor Heating System		YES	YES	YES
Cascade Operation		256 units max.	256 units max.	256 units max.
Freezing Protection		YES	YES	YES
Schedule Programming / Vacation Mode		YES	YES	YES
Parameter Setting Terminal		User Display / PC	User Display / PC	User Display / PC



Manufacturer reserves the right to change any product specifications without notice.

**ALARKO**



**ALARKO CARRIER  
SANAYİ VE TİCARET A.Ş.**

GOSB-Gebze Organize Sanayi Bölgesi  
Şahabettin Bilgisu Cad. 41480 Gebze-Kocaeli/TURKEY  
**Phone :** (90)(262) 648 60 00 PBX  
**Telefax :** (90)(262) 648 61 01  
**web :** www.alarko-carrier.com.tr  
**e-mail :** info@alarko-carrier.com.tr



A.4.1.15 i 170616 MINERAL